



3 6 0 ° F R O M P E L L E T T O P A L L E T E X P E R T I Z E

FILLING TECHNOLOGY

SIPA BERCHI

All the various types of filler can be coupled in Sincro-Bloc with SIPA rotary blowers, for an integrated blowing - filling - capping solution.



A careful study of plant engineering, the ergonomic design, a complete and simple operator interface and a fully automatic configuration of work process flows make these solutions easy to use and manage.

The monoblock is completed with the addition of mechanical and electronic rinsers, equipped with various types of treatment according to the different plant and equipment choices, and with cappers for plastic, aluminium and twist-off caps and other types of cap.

A version equipped with laminar flow cabinet is also available to meet the requirements of customers who need to comply with specific sanitary classes in accordance with international benchmark regulations.



The structure of the entirely stainless steel basement frame is fully modular for the whole range and was designed with great care to achieve the highest levels of sanitizability of the structural surfaces. The upper level is double sloping for complete draining of possible residues of product, water, fragments, bottles, caps, etc.



Stillfill S

Gravity filling monoblock

Stillfill S is a mechanical gravity filling machine, for PET and glass bottles, made for cold filling with still water and non-carbonated products.

Products that can be processed

- Non-carbonated mineral water.
- Non-carbonated beverages and juice.

Main features

- Central tank.
- Entirely stainless steel (grade 304) draining base.
- Reliable, simple and easily sanitized valve.
- Reduced changeover down-times.
- Pneumatic filling valve opening/closing controls, no electronics in the machine.
- PET bottle transfer - neck-handling - with no need for monoblock height adjustment.
- Possibility of installing a level control system.

Output

Fillers with from 16 to 120 valves from 4,800 to 52,000 b/hour on 1.5 litres with still water.

Models

- Stillfill S P for PET containers and Stillfill S V for glass containers.
- Stillfill SL version without siphon.

Plus

- Product deflection without deflector (swirling device).
- No dynamic gaskets in contact with the product: the shutter is sealed by a simple bellows diaphragm.
- Simple to operate.
- Evacuation to the outside of air returning from the bottles to prevent possible pollution.
- Valves made entirely of AISI 316 stainless steel.
- Quick changeover for packages with different diameters.



Non-carbonated mineral water

Clear juice

Juice with fibre or pulp

Isotonic and sport drinks

Tea

Milk and milk by-products

Alcoholic beverages

Sensitive products must be protected from possible contamination. The characteristics of the valve (extreme simplicity and sanitizability), the configurations of the monoblock with laminar flow cabinets up to class 100

(ISO 5) and specific sterilization treatments on containers and caps create suitable conditions for processing these products.



Filling valve

Extremely fast, simple and reliable patented mechanical valve.

It is operated by a pneumatic control located inside the movement carriage, so allowing control of the opening and closing phases. The control is not in contact with the product so as to prevent any possibility of contamination.



Hygiene

No dynamic gaskets in contact with the product. Small number of static gaskets, all fitted in open groove (and therefore fully sanitizable).

No wells or dead areas inside in order to prevent possible stagnation of product and increase efficiency of washing cycles.

The downward movement of the valve and its seal on the bottle takes place due to the weight of the valve itself. The absence of springs is a fundamentally important aspect with regard to hygiene and maintenance.

Sanitation cycle with the use of dummy bottles. Fitting and removal of these takes place in an extremely simple and functional way by means of a special bayonet connection to avoid direct contact between operator and valve.

Circuit preset for high temperature CIP.



Stillfill R\HR

Hot fill monoblock

Stillfill R\HR is a mechanical gravity filling machine with recirculation for PET and glass bottles. Designed for HOT FILL (up to 95 °C) and more generally for all non-carbonated beverages that require filling with recirculation.

Products that can be processed

- Tea.
- Fruit juice (with or without pulp).
- Isotonic drinks.
- Functional beverages.

Main features

- Feeding from the bottom of the central manifold for product distribution from an external tank.
- Entirely stainless steel (grade 304) draining base.
- External tank for recovery of recirculated product.
- Reliable, simple and easily sanitized valve.
- Reduced changeover down-times.
- Pneumatic filling valve opening/closing controls, no electronics in the machine.
- Very small recirculation amount in valve to maintain the temperature in the event of a machine stoppage.
- PET bottle transfer - neck-handling - with no need for monoblock height adjustment.

Output

Fillers with from 16 to 120 valves
from 4,800 to 32,000 b/hour on 1.5 litres
with fruit juice.

Models

- Stillfill R\HR P for PET containers and
- Stillfill R\HR V for glass containers.

Plus

- Product deflection without deflector (swirling device).
- Very small number of gaskets and seals.
- Possibility of managing pulp up to 3 mm in diameter and 10 mm in length.
- Constant and controlled recirculation in bottle.
- Simple to operate.
- Possibility of handling "ultralight" bottles.
- Reduction of pressure in the bottle (no "fat-boy" or "splash out" effect).
- The air returning from the bottle during filling is evacuated to the outside through the recirculation channel. No possible contamination of the product.
- Valves made entirely of AISI 316 stainless steel.
- Quick changeover for packages with different diameters.



Carbonated
mineral water

Clear
juice

Juice
with fibre or pulp

Isotonic
and sport drinks

Tea

Hot filled
products

Alcoholic
beverages

With Stillfill HR, it is possible to keep the amount of recirculated product stable regardless of the formats handled.

Thanks to the pneumatic valve opening/closing control system, it is simply sufficient to set the bottle size in the operator panel.



Hygiene

No dynamic gaskets in contact with the product. Small number of static gaskets, all fitted in open groove (and therefore fully sanitizable).

No wells or dead areas inside in order to prevent possible stagnation of product and increase efficiency of washing cycles.

The absence of springs in the down element of the valve is a fundamentally important aspect with regard to hygiene and maintenance.

Sanitation cycle with the use of dummy bottles.

Fitting and removal of these takes place in an extremely simple and functional way by means of a special bayonet connection to avoid direct contact between operator and valve.

Circuit preset for high temperature CIP.

Filling valve

Extremely fast, simple and reliable patented mechanical valve. It is operated by a pneumatic control located inside the movement carriage, so allowing control of the opening and closing phases. The control is not in contact with the product so as to prevent any possibility of contamination. The valve allows filling with products containing large pieces of pulp and fibre. Possibility of filling "to brim". The filling process has been designed to maintain the temperature of the whole circuit (valves, tanks, pipes) even in the event of long stops.





Isofill

Isobaric filling monoblock

Isofill P, mechanical level filler for carbonated products in PET bottles, was designed adopting advanced technologies. It has an innovative design and is equipped with special features for both filling and moving the bottles, which guarantee great advantages in terms of performance and operating flexibility. The valve is also able to fill non-carbonated products.

Products that can be processed

- Carbonated mineral water and CSDs.
- Still water.
- Beer.

Main features

- Central tank.
- Entirely stainless steel (grade 304) draining base.
- Valve with height adjustable moving filling tube to define the level in the bottle.
- Reliable, simple and easily sanitized valve.
- Reduced changeover down-times.
- PET bottle transfer - neck-handling - with no need for monoblock height adjustment.

Output

Fillers with from 16 to 160 valves from 2,800 to 35,000 b/hour on 1.5 litres with CSD.

Models

- Isofill P for PET containers and Isofill V for glass containers.
- Isofill P P and V P with double circuit for flushing and pre-evacuation.

Plus

- Product deflection without deflector (swirling device).
- A single filling tube for all the formats.
- Automatically engaged dummy bottles.
- Manifoldd decompression carried out with the filling tube raised.
- Quick changeover for packages with different diameters.



Non-carbonated mineral water

Carbonated mineral water

Carbonated beverages

Clear juice

Isotonic and sport drinks

Tea

Beer

Swirl

For a long time, we have been making an innovative "internal deflection" system standard on our PET fillers so avoiding the deflector on the filling tube, and therefore there is no need for

adaptation of the filling tube to the inside of the bottle neck during a format change.

A homogeneous film of product is deflected inside the container without turbulence or foam regardless of the shape, design, size or weight of the bottle.



Filling valve

A mechanical level valve with extremely reliable and sturdy moving filling tube, which requires very little maintenance. It consists of a limited number of components and has been designed for a complete sanitation, to avoid every possible area of product stagnation. The valve is extremely versatile and allows different containers to be handled without format change parts. The only adjustment is the re-positioning of the filling tube that takes place simultaneously for all the valves with a centralized control. The valve is complete with decompression button and centralized circuit for discharge of the snift. This operation takes place with the filling tube lifted and allows initial pressurization of the bottle and final de-pressurization to be carried out in clean filling tube conditions, so avoiding possible turbulence caused by nebulized product put into the bottle.



Hygiene

The sanitation phase is very simple and is fully automatic, by means of a control on the operator panel: the machine prepares itself for the electro-pneumatic control of all the on-off valves. The sanitation cycle is carried out in such a way that the solution laps against all the internal areas of the filler with forced flows.

Automatic dummy bottles:

Thanks to the moving filling tube that characterizes the filling valve, it was possible to make an engagement/disengagement system with extremely simple and functional electro-pneumatic control that ensures there is no contact between operator and machine.



Isotronic

Isobaric volumetric filling monoblock

Isotronic P is an electronic volumetric filler for bottling carbonated and non-carbonated liquid products in PET bottles. The machine is particularly suitable for filling of homogeneous liquids such as soft drinks, water and clear juice.

Products that can be processed

- Carbonated mineral water and CSDs.
- Still water.
- Clear juice.

Main features

- Central tank.
- Valve with magnetic flow meter for definition of the content in the bottle.
- Entirely stainless steel (grade 304) draining base.
- No filling tube.
- Reduced changeover down-times.
- Simple to operate with selection of the various products/formats directly from the operator panel.
- PET bottle transfer - neck-handling - with no need for monoblock height adjustment.

Models

- Isotronic P for PET containers.
- Isotronic P P with double circuit for flushing and pre-evacuation.

Plus

- Product deflection without deflector (swirling device).
- High content precision.
- Automatically engaged dummy bottles.
- Manifoldded decompression.
- Quick changeover for packages with different diameters.

Output

Fillers with from 50 to 160 valves
from 10,000 to 35,000 b/hour on 1.5 litres
with CSD.



Non-carbonated mineral water

Carbonated mineral water

Carbonated beverages

Clear juice

Isotonic and sport drinks

Tea

Beer

Great precision of bottled product!
This filling technology is particularly suitable for PET containers: during the pressurizing phase, there can be dimensional changes in the bottle that therefore

make it difficult to control the content using traditional methods.



Filling valve

Electronic valve with volumetric filling managed through a magnetic flow meter situated on the filling valve without filling tube. This solution ensures high precision in the amount of liquid in the bottle. The valve is complete with decompression button and centralized circuit for manifolded discharge of the snift.

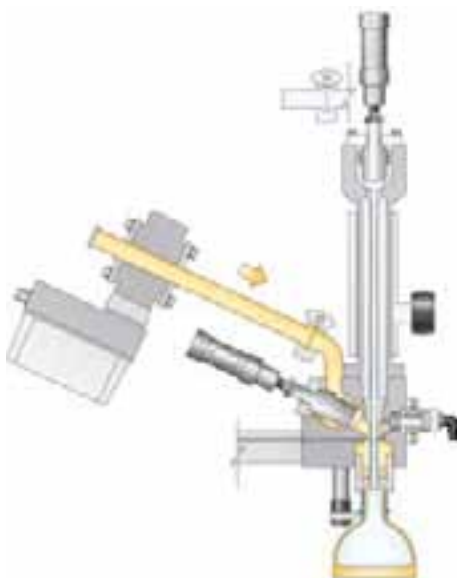

Hygiene

The sanitation phase is very simple and is fully automatic, by means of a control on the communication keyboard: the machine prepares itself for the electro-pneumatic control of all the on-off valves. The sanitation cycle is carried out in such a way that the solution laps against all the internal areas of the filler with forced flows.

Automatic dummy bottles:

Thanks to the configuration of the filling valve, it is possible to make an engagement/disengagement system with extremely simple and functional electro-pneumatic control, which ensures there is no contact between operator and machine. Circuit preset for high temperature CIP.



Unitronic

Volumetric gravity filling monoblock

Unitronic P is an electronic volumetric filler for bottling still liquid products in PET bottles. The machine is particularly suitable for filling with homogeneous liquids and, thanks to the characteristics of the valve, can be configured in ULTRA CLEAN version.

Products that can be processed

- Sensitive products (fresh or micro-filtered milk, drinking yoghurt, etc.).
- Still water.
- Clear juice.
- Alcoholic beverages.

Main features

- External tank.
- Valve with magnetic flow meter for definition of the content in the bottle.
- Entirely stainless steel (grade 304) draining base.
- Possibility of hot filling products without recirculation.
- No filling tube.
- Reduced changeover down-times.
- Simple to operate with selection of the various products/formats directly from the operator panel.
- PET bottle transfer - neck-handling - with no need for monoblock height adjustment.

Output

Fillers with from 16 to 120 valves
from 2,800 to 48,000 b/hour on 1.5 litres
with water.

Models

- Unitronic P for PET containers.
- Unitronic P UC Ultra Clean version.

Plus

- Extremely clean filling: no contact between valve and bottle.
- Possible configuration for filling in ULTRA CLEAN.
- Filling speed can be adjusted to suit the product.
- High content precision.
- The air in the bottle does not come into contact with the product feeding circuit.
- All parts in contact with the product are made of AISI 316L steel.
- Quick changeover for packages with different diameters.



Non-carbonated
mineral water

Clear
juice

Isotonic
and sport drinks

The

Milk and
milk by-products

Alcoholic
beverages

Ultra Clean

This extremely clean valve is ideal for the configuration of monoblocks for cold filling very sensitive products such as milk and milk by-products, juice without preservatives, etc.

in Ultra Clean conditions. In this case, the monoblock will be equipped with a class 100 laminar flow cabinet, a cap sterilization system and, in addition to the traditional rinser, a container sterilizer.



Filling valve

On/off diaphragm valve that guarantees there is no contact between product and external environment.

Electronic valve with volumetric filling managed through a magnetic flow meter situated on the filling valve that does not have a filling tube. This solution ensures high precision in the amount of liquid in the bottle.

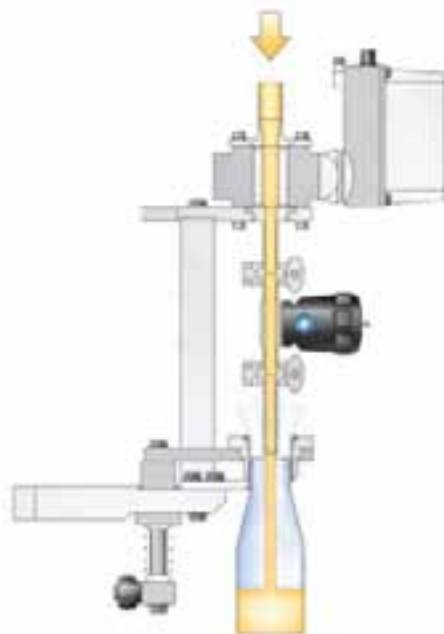

Hygiene

Extreme sanitizability is one of the most important elements of this valve, characterized by a limited number of components and of moving parts.

The sanitation phase is very simple and is fully automatic, by means of a control on the communication keyboard: the cycle is carried out in such a way that the solution laps against all the internal areas of the filler with forced flows.

The dummy bottles are loaded manually. Circuit preset for CIP and SIP up to 100 °C.



Bigfill

Volumetric gravity filling monoblock for large sizes

Bigfill is an electronic rotary volumetric filler for bottling still liquid products in large PET bottles. The machine is optimized for moving and filling large formats (up to 10 litres).

Products that can be processed

- Still water.

Main features

- External tank.
- Product ring buffer situated above the valves.
- Valve with magnetic flow meter for definition of the content in the bottle.
- Designed for filling large formats (5 - 8 - 10 litres).
- No filling tube.
- During filling, the bottle is kept in position by a mechanical gripper.
- Inside the monoblock, the bottles are moved by the bottom.
- Simple to operate with selection of the various formats directly from the operator panel.

Plus

- Extremely clean filling: no contact between valve and bottle.
- High filling speed.
- Motor-driven height adjustment for various formats.
- High content precision.
- The air in the bottle does not come into contact with the product feeding circuit.
- All parts in contact with the product are made of AISI 316L steel.

Output

Fillers with from 8 to 20 valves
from 2,800 to 7,500 b/hour on 5 litres with water.



Non-carbonated
mineral water

Filling speed modulation

Double speed filling with final partialization phase is obtained by means of a two position actuator. The high filling speed is guaranteed by the pressurization

of the feed ring placed above the valves. The duration of the partialization phase is automatically adjusted according to the format to obtain the highest production efficiency. This optimization is particularly

important for filling large formats where high speeds are reached, whose optimization particularly in the final phase avoids the "splash out" effect.



Filling valve

On/off diaphragm valve with flow partialization that guarantees there is no contact between product and external environment.

Electronic valve with volumetric filling controlled by a magnetic flow meter placed on the filling valve without filling tube. The partialization phase that precedes the final closing ensures high precision in the amount of liquid measured into the bottle.

The nozzle with wide pass-through sections was designed to obtain the highest flow through the mouth of the bottle and minimize the turbulence of the product particularly during the final phase of filling to the top.

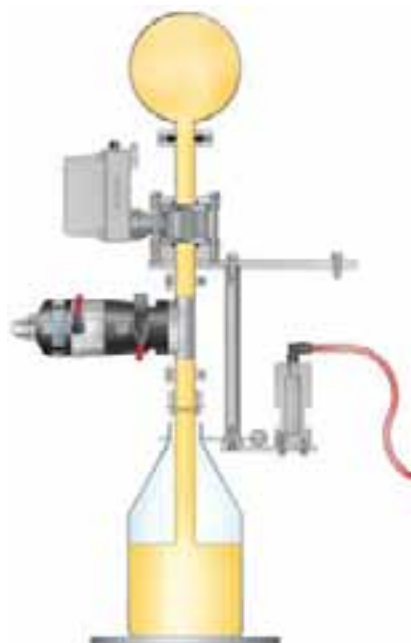

Hygiene

Extreme sanitizability is one of the most important elements of this valve, characterized by a limited number of components and of moving parts.

The sanitation phase is very simple and is managed fully automatically through a control on the communication keyboard: the cycle is carried out in such a way that the solution laps against all the internal areas of the filler with forced flows.

The dummy bottles are loaded manually. Circuit preset for CIP and SIP up to 100 °C.



FILLING TECHNOLOGY

SIPA S.p.A.

Via Caduti del Lavoro, 3
31029 Vittorio Veneto (TV) ITALY
Tel: +39 0438911511
Fax: +39 0438912273
E-mail: sipa@zoppas.com
Website: www.sipa.it

SIPA-BERCHI GROUP S.p.A.

Via Provinciale, 36
43038 Sala Baganza (PR) ITALY
Tel: +39 0521548111
Fax: +39 0521548112
E-mail: berchi@zoppas.com
Website: www.berchigroup.com

SIPA RUSSIA

Ul. Ordzhonikidze, 11 Str. 1/2
115419 Moscow - RUSSIA
Tel: +7 495 2324191
Fax: +7 495 2324190
E-mail: sipa_russia@co.ru

SIPA UKRAINE

Office 37, 9 Turovs'ka St., Kyiv
254655 Kiev - UKRAINE
Tel: +38 044 4636817
Fax: +38 044 4257275
E-mail: sipa.ukraine@zoppas.com

SIPA ENGINEERING S.r.l.

Str. Mangalia, 61
300186 Timisoara - ROMANIA
Tel: +40 356 434200
Fax: +40 356 434280
E-mail: sipa.romania@zoppas.com

SIPA TURKEY

SIPET
Kisikli Caddesi No: 2 A Blok Kat:3
34662 Altunizade - Uskudar - Istanbul
TURKEY
Tel: +90 216 4749780
Fax: +90 216 4749779
E-mail: sipet@sipet.com.tr

SIPA NORTH AMERICA

3800 Camp Creek Parkway
Building 2400, Suite 106
Atlanta, Georgia 30331 - U.S.A.
Tel: +1 404 3493966
Fax: +1 404 3493858
E-mail: sales@na.sipa.it

SIPA SUL AMERICA Ltda

Wt Empresarial Parque
Av. Gupê, 10.767 - Galpão 08 Bloco II
Jardim Belval
06422-120 Barueri - SP - BRAZIL
Tel: +55 11 47728300
Fax: +55 11 47728301
E-mail: sipa@sipa.com.br

SIPA ANDINA Ltda

Avenida El Dorado 68 C 61
Oficina 628, Piso 6
Bogota, Colombia
Tel: +571 479 5252
Fax: +571 4763444
Email: Sipa_Andina@zoppas.com

SIPA JAPAN Ltd.

Komai Bldg. 2F, 3-2-9 Nihombashi Muromachi,
Chuo-ku, Tokyo 103-0022, JAPAN
Tel: +81 352554848
Fax: +81 352554849
E-mail: tanigaki@sipajapan.com

SIPA CHINA

19/F, unit 1905, Zhong Yu Plaza,
No. jia-6 Gongtibei Road,
Chaoyang District
100027 Beijing - CHINA
Tel: +86 10 65120447 - 48
Fax: +86 10 65120449
E-mail: sipachina@sipacina.com.cn

SIPA MACHINERY HANGZHOU

3 Road 14, Economic & Technology Development Zone
310018 Hang Zhou, Zhejiang province - CHINA
Tel: +86 571 86913106
Fax: +86 571 86913548

SIPA THAILAND

Bangna Complex 947/150 4th Floor,
Moo 12 Bangna - Trad Road,
Bangna
Bangkok 10260 - THAILAND
Tel: +66 27695451
Fax: +66 27695452
E-mail: sipa.fareast@zoppas.com

SIPA INDIA

B 101, Mangalya
Off Marol Maroshi Road
Marol, Andheri (East)
Mumbai - INDIA 400 059
Tel: +91 22 29201785
Fax: +91 22 29201795
E-mail: sipa.india@zoppas.com